



Parts conveyors are widely used to convey chips, slugs or scrap materials to hoppers or other containers for disposal or recycling. Model PC, at left is shown with nitrile belt.



PC at right includes wire mesh belting.

Each PC is supplied with flapper gate at infeed end and right hand drive.

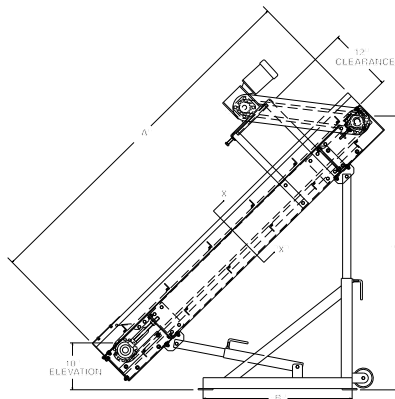
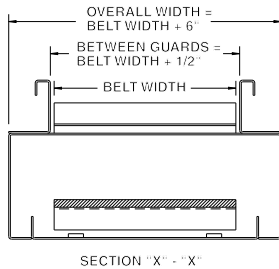

SPECIFICATIONS

BELTING: 3-ply black nitrile belt with 1-1/2" high molded cleats on 12" centers; 1/2" x 1" flat wire mesh belt with 1-1/2" high galv. cleats on 12" centers. **NOTE:** Units with 6" wide belt not available with wire mesh belt.

DRIVE PULLEY: 4" dia. with 1-3/16" dia. shaft, crowned and fully lagged.

TAIL PULLEY: 4" dia., crowned, with 1-3/16" dia. shaft.

BELT RETURN: Formed steel slide retains belt and cleats inside bed.

BEARINGS: All pulley bearings are precision, heavy duty, lubricated, ball bearing units with cast iron housings.

BELT SPEED: 60 FPM, constant.

BED: 7" deep x 12 ga. one piece formed box-type construction.

TAKE-UP: Screw type unit at tail pulley provides 12" belt take-up.

PORTABLE SUPPORT: 4" dia. casters, tubular construction, adjustable both ends.

GUARD RAILS: 3-1/2" high x 12 ga. formed steel with gate at infeed.

MOTOR DRIVE: 1/3 HP, 230/460/3, 60 cycle, ODP right angle gear motor.

CAPACITY: 330 lbs. total distributed live load at 60 FPM.

ELECTRICAL CONTROLS: Optional.

OPTIONAL EQUIPMENT

DRIVE CLEARANCE: Motor drive may be mounted higher above bed or underneath bed for additional clearance.

FLOOR SUPPORTS: Permanent, adjustable supports available. Consult factory.

BELT SPEED: Constant speed 10 to 60 FPM; DC variable speed; AC inverter variable speed. Other constant or variable speeds available. **NOTE: CAPACITY CHANGES WITH SPEED.**

MOTORS: Available through 1 HP in TEFC, explosion proof, dirty duty, 115/230/1, 575/3, etc.

ELECTRICAL CONTROLS: Magnetic starter; manual starter; momentary start/stop push button station; mounting and pre-wiring for units 12'-0" long and under; limit switch; photo relay; others available.

NOTE: Minimum parts size of 1/2" cube for nitrile belt, 1" cube for flat wire mesh belt.

BELT		*6"	8"	12"	18"	24"	
BED		12"	12"	18"	24"	30"	
"A"	"B"	"C" MAX.	UNIT WEIGHTS (lbs.)				
4'	18"	36"	413	417	480	568	618
6'	30"	56"	447	451	515	605	659
7'	36"	61"	465	469	575	626	688
9'	48"	78"	502	506	595	665	723
11'	60"	95"	539	543	615	704	764

*NOTE: Units with 6" wide belt not available with wire mesh belt.



■ 3 week shipment